

DISTINTA DELLE PARTI COSTITUENTI LE POMPE ROTATIVE VOLUMETRICHE SERIE "V"
SPARE PARTS LIST FOR "V" SERIES POSITIVE-DISPLACEMENT ROTARY PUMPS
LISTE DES PIÈCES DE RECHANGE POUR POMPES ROTATIVES VOLUMÉTRIQUES SERIE "V"
ERSATZTEILLISTE FÜR SELBSTANSAUGENDE INNENZAHNRADPUMPEN SERIE "V"

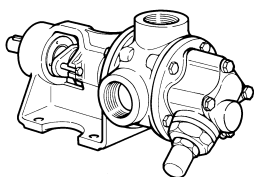

V 25-2 SPG Code 1000 9885

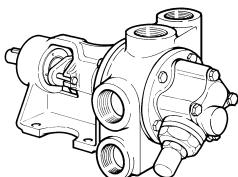

V 25-2 SPHTR Code 1000 9896

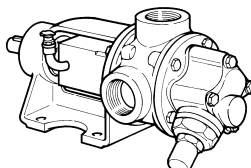

V 25-2 ST5WG Code 1000 9907
 V 25-2 ST5BS Code 1000 9899
 V 25-2 ST5K Code 1000 9945

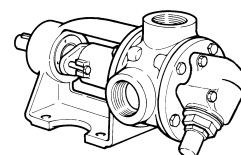

V 25-2 SPK Code 1000 9958

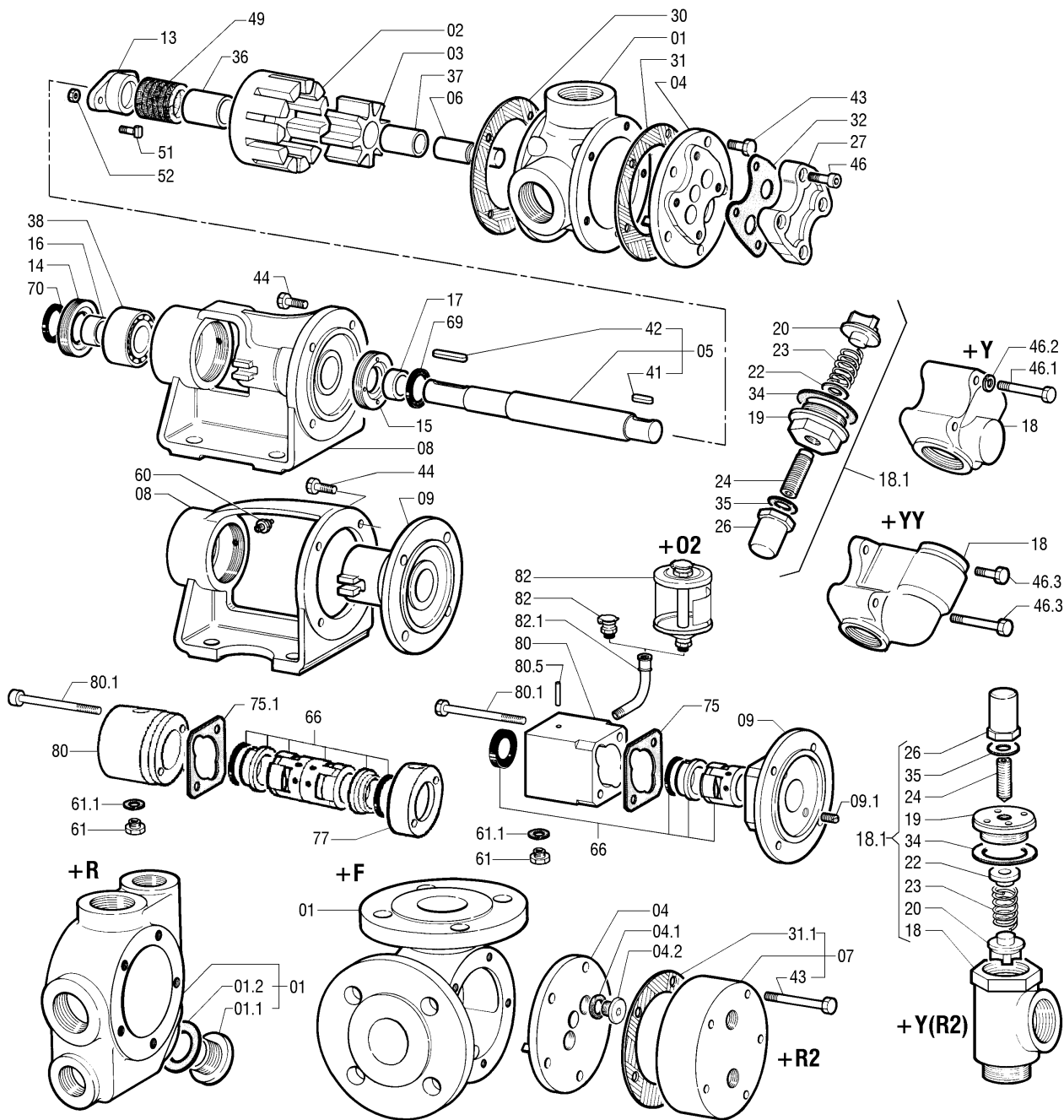

Rif. N° Pos. Nr.	Quant.	Denominazione	Part name	Den. Comm. Type	Mat.*	Codice Vecchio Old Part. no.	Codice Nuovo New Part. no.	V 25-2 SPG	V 25-2 SPHTR	V 25-2 ST5WG	V 25-2 ST5BS	V 25-2 SPK	V 25-2 ST5K	V 25-2 ST8K
01	1	Corpo	Casing		G	3319 3001	1000 4919	○		○	○			
					GS	3319 3002	1000 4920	①		①	①			
		(1)	(1)		GS	3319 3006	1000 8051	②	○	②	②			
		K	3319 5020		1000 4993					○	○	○		
		K	3319 5025		1000 5001					①	①	①		
01.1	1	Tappo	Plug	R1" DIN 908	S	1671 4006	1000 2412	②	○	②	②			
01.2	1	Guarnizione	Gasket	33 x 39 x 2	E3	3450 0605	1000 5661	②	○	②	②			
02	1	Rotore	Rotor		GS	3765 3030	1000 6605	○	○	○	○			
					K	3765 5025	1000 6691					○	○	○
03	1	Ruota oziosa	Idler		G	3780 3035	1000 6755	○	○	○				
					GH	3780 3033	1000 6753				○			
					K	3780 5018	1000 6829					○	○	○
04	1	Coperchio	Cover		G	3270 3000	1000 4664	○	○	○	○			
					K	3270 5027	1000 4750					○	○	○
					K	3270 5029	1000 4753					③	③	③
04.1	2	Guarnizione	Gasket	1/2"	E3	3450 0601	1000 5658					③	③	③
04.2	2	Tappo	Plug	R 1/2" DIN 908	K	1671 5004	1000 2415					③	③	③
05	1	Albero (2)	Shaft (2)	D.22	SH	5032 4000	1000 7615	○	○	○				
					K9	5032 5023	1000 7627				○	○	○	○
06	1	Perno	Idler pin	D. 20	T3	3540 4002	1000 5893	○	○	○				
					K9	3540 5034	1000 5939				○	○	○	○
07	1	Camera di prerisc. (3)	Heating jacket (3)			5135 4000	1000 7775					③	③	③
08	1	Supporto	Bearing housing		G	3872 3000	1000 6886	○	○					
					G	3872 3001	1000 6887				○	○	○	○
09	1	Flangia supporto	Rear cover		G	3375 3001	1000 5145			○	○			
					K	3375 5000	1000 5171					○		
					K	3375 5004	1000 5172						○	
					K	3375 5031	1000 5183							○
09.1	2	Vite	Screw	M 10 x 10	K	1470 5000	1000 1877						○	
13	1	Premitreccia	Gland		G	3690 3000	1000 6513	○	○					
					K	3690 5000	1000 6523					○		
14	1	Copricuscinetto	Bearing cover		G	3287 3000	1000 4790	○		○	○	○	○	○
					G	3287 3002	1000 4792	②	○	②	②			
15	1	Copricuscinetto	Bearing cover		G	3287 3001	1000 4791	○		○	○	○	○	
					G	3287 3003	1000 4793	②	○	②	②			
					G	3287 3034	1000 4818							○
16	1	Ghiera	Sleeve	20 x 26 x 12,5	S	3107 4501	1000 4238	○	○	○	○	○	○	
17	1	Ghiera	Sleeve	20 x 26 x 10,5	S	3107 4507	1000 4243	○	○	○	○	○	○	
18	1	Corpo By-pass	By-pass casing		G	3240 3007	1000 4452	④	④	④	④			
					G	3240 3010	1000 4454	⑤	⑤	⑤	⑤			
					K	3240 5088	1000 4547					④	④	④
					K	3240 5011	10004499					⑦	⑦	⑦
18.1	1	By-pass	By- pass		G	5090 3001	1000 7734	④	④	④	④			
					G	5090 3020	1000 7743	⑤	⑤	⑤	⑤			
					K	5090 5028	1000 7770					④	④	④
					K	5090 5001	1000 7756					⑦	⑦	⑦
19	1	Coperchio By-pass	By-pass cover		G	3240 3000	1000 4448	④	④	④	④			
	2				G	3240 4000	1000 4477	⑤	⑤	⑤	⑤			
	1				K	3240 5076	1000 4540					④	④	④
	1				KNM	3240 5005	1000 4495					⑦	⑦	⑦
20	1	Valvola By-pass	By-pass check valve		H2	3240 5024	1000 4507	④	④	④	④			
	2				H2	3240 4016	1000 4490	⑤	⑤	⑤	⑤			
	1				K	3240 5078	1000 4542					④	④	④
	1				K	3240 5025	1000 4508					⑦	⑦	⑦
22	1	Rondella By-pass	By-pass washer		S	1450 4016	1000 1699	④	④	④	④			
	2				S	1450 4016	1000 1699	⑤	⑤	⑤	⑤			
	1				K	1450 5003	1000 1706					④	④	④
	1				K	3240 5017	1000 4503					⑦	⑦	⑦

Rif. N° Pos. Nr.	Quant.	Denominazione	Part name	Den. Comm. Type	Mat.*	Codice Vecchio Old Part. no.	Codice Nuovo New Part. no.	V 25-2 SPG	V 25-2 SPHTR	V 25-2 ST5WG	V 25-2 ST5BS	V 25-2 SPK	V 25-2 ST5K	V 25-2 ST8K
23	1	Molla By-pass	By-pass spring	D. 3 x 16,3 x 50 x 6	S	3495 4010	1000 5783	④	④	④	④			
	2			D. 3 x 16,3 x 50 x 6	S	3495 4010	1000 5783	⑤	⑤	⑤	⑤			
	1			D. 3,8 x 17 x 49 x 8,5	K	3495 5009	1000 5799					④	④	④
	1			D. 4 x 20 x 72 x 6,7	K	3495 5017	1000 5804					⑦	⑦	⑦
24	1	Vite By-pass	By-pass screw	M 16 x 50 DIN 915	S	3240 4005	1000 4481	④	④	④	④			
	2			M 16 x 50 DIN 915	S	3240 4005	1000 4481	⑤	⑤	⑤	⑤			
	1			M 16 x 50 DIN 915	K	3240 5077	1000 4541					④	④	④
	1			M 12 x 50 DIN 914	K	3240 5032	1000 4513					⑦	⑦	⑦
26	1	Cappello By-pass	By-pass cap		S	3240 2001	1000 4442	④	④	④	④			
	2				S	3240 2001	1000 4442	⑤	⑤	⑤	⑤			
	1				K	3240 5075	1000 4539					④	④	④
	1				K	3240 5000	1000 4493					⑦	⑦	⑦
27	1	Flangia By-pass	By-pass flange		G	3362 3000	1000 5123	○	○	○	○			
					K	3362 5007	1000 5143					○	○	○
30 (**)	1	Guarnizione corpo	Casing gasket											
31 (**)	1	Guarnizione coperchio	Cover gasket	87 x 123 x 0,5 -5F										
31.1	1	Guarnizione	Gasket	87 x 123 x 0,5 -5F	E3	3450 0100	1000 5520					③	③	③
32 (**)	1	Guarnizione	Gasket											
34	1	Guarnizione	Gasket	43 x 55 x 0,5	E3	3450 0016	1000 5501	④	④	④	④			
	2			36 x 47 x 0,5	E3	3450 0017	1000 5502	⑤	⑤	⑤	⑤			
	1			36 x 47 x 0,5	E3	3450 0017	1000 5502					④	④	④
	1			40 x 55 x 0,5	E3	3450 0015	1000 5500					⑦	⑦	⑦
35	1	Guarnizione cappell.	Cap gasket	17 x 27 x 0,5	E3	3450 0011	1000 5497	④	④	④	④	④	④	④
	2			17 x 27 x 0,5	E3	3450 0011	1000 5497	⑤	⑤	⑤	⑤			
	1			13 x 24 x 0,5	E3	3450 0029	1000 5512					⑦	⑦	⑦
36	1	Bronzina supporto	Bearing bush	22 x 30 x 35	G	3120 3036	1000 4359	○		○				○
					B4	3120 2012	1000 4301		○					
					GR	3120 0021	1000 4270				○	○	○	
37	1	Bronzina ruota oziosa	Idler bush	20 x 25 x 31	G	3120 3035	1000 4358	○		○				○
					B4	3120 2000	1000 4300		○					
					GR	3120 0010	1000 4262				○	○	○	
38	1	Cuscinetto	Ball bearing	3304 HT	S	1418 0092	1000 1389	○	○	○	○	○	○	○
41	1	Linguetta	Key	6 x 6 x 20 DIN 6885A	S	1434 4007	1000 1587	○	○	○				○
					K	1434 5003	1000 1620				○	○	○	
42	1	Linguetta	Key	6 x 6 x 36 DIN 6885A	S	1434 4008	1000 1588	○	○	○	○	○	○	○
43 (*)	5	Vite	Screw	M 8 x 20 DIN 933	S			○	○	○	○			○
				M 8 x 25 DIN 933	K							○	○	
				M 8 x 60 DIN 933	K	1478 5020	1000 2038					③	③	③
44 (*)	4	Vite	Screw	M 8 x 20 DIN 933	S			○	○					
				M 8 x 25 DIN 933	S					○	○			○
				M 8 x 25 DIN 933	K							○	○	
46 (*)	4	Vite	Screw	M 8 x 18 DIN 912	S			○	○	○	○			○
				M 8 x 16 DIN 933	K							○	○	
46.1	4	Vite	Screw	M 8 x 60 DIN 931	S	1478 4018	1000 1944	④	④	④	④			
	2			M 8 x 20 DIN 912	K	1476 5026	1000 1923					④	④	④
	2			M 8 x 65 DIN 912	K	1476 5028	1000 1924					④	④	④
46.2	4	Rondella	Washer	M 8 DIN 127B	S	1448 4003	1000 1679	④	④	④	④			
46.3	2	Vite	Screw	M 8 x 20 DIN 933	S	1478 4010	1000 1937	⑤	⑤	⑤	⑤			
	2			M 8 x 55 DIN 933	S	1478 4017	1000 1943	⑤	⑤	⑤	⑤			
49	1	Baderna	Packing	22 x 34 x 6	TE	5060 0005	10007640	○				○		
				22 x 34 x 6 UP3075		5060 0015	10007645	②	○			②		
51	2	Vite	Screw	M 6 x 45 DIN 933	S	1478 4008	1000 1935	○	○					
					K	1478 5006	1000 2025					○		
52	2	Dado	Nut	M 6 DIN 934	S	1420 4003	1000 1419	○	○					
					K	1420 5002	1000 1433					○		
60 (*)	1	Ingrassatore	Grease nipple	M 6	S			○	○	○	○	○	○	○

Rif. N° Pos. Nr.	Quant.	Denominazione	Part name	Den. Comm. Type	Mat. *	Codice Vecchio Old Part. no.	Codice Nuovo New Part. no.	V 25-2 SPG	V 25-2 SPHTR	V 25-2 ST5MG	V 25-2 ST5BS	V 25-2 SPK	V 25-2 ST5K	V 25-2 ST8K	
61	3	Tappo	Plug	R 1/4" DIN 908	S	1671 4002	1000 2410			○	○				
	1				S	1671 4002	1000 2410						○		
	3				K	1671 5002	1000 2414							○	
61.1	3	Guarnizione	Gasket	1/4"	D	3450 0600	1000 5657			○	○		○		
	1				D	3450 0600	1000 5657							○	
66	1	Tenuta completa	Mechanical seal	N 22 WCT - FL		5919 4002	1000 8942			○					
				N 22 GCT - FL		5919 4000	1000 8940			○		○			
				N 22 WCT/GCT		5917 4002	1000 8909							○	
69	1	Paraolio	Oil seal	DH 26 x 34 x 4		1406 6000	1000 1252	○		○	○	○	○	○	
70	1	Paraolio	Oil seal	DH 26 x 34 x 4		1406 6000	1000 1252	○		○	○	○	○	○	
75 (**)	1	Guarnizione	Gasket	58 x 95 x 0,5											
75.1	1	Guarnizione	Gasket	58 x 95 x 0,5	E3	3450 0371	1000 5623							○	
77	1	Portatenuta	Seal box		K	3615 5326	1000 6228							○	
80	1	Portatenuta	Seal box		G	3615 3327	1000 6185			○	○				
					K	3615 5327	1000 6229							○	
					K	3615 5317	1001 7566							○	
80.1	2	Vite	Screw	M 8 x 80 DIN 931	S	1478 4022	1000 1946			○	○				
				M 8 x 80 DIN 931	K	1478 5023	1000 2041						○		
				M 8 x 80 DIN 931	K	1476 5022	1000 1920							○	
80.5	1	Spina	Spring pin	3 x 20	H	1463 5008	1000 1785			○	○		○		
				3 x 10 UNI 6873	H	1463 5003	1000 1782							○	
82	1	Oliatore	Oil lubricator	R 1/4" KLG 4	S	1444 0053	1000 1671			○	○		○		
				R 1/4"		1444 0055	1000 1672			⊗	⊗		⊗		
82.1	1	Curva	Elbow	R 1/4"	G	1601 3002	1000 2292			○	○		○		
(*)		Serie viterie	Set of screws				1001 5166	○	○						
							1001 5167			○	○			○	
							1001 5168					○	○		○
(**)		Serie guarnizioni	Set of gaskets			E3	1001 4954	○	○			○			
						E3	1001 4955			○	○		○		○

Note:

- 1) Completo di guarnizione (01.2) e tappo (01.1).
- 2) Completo di linguette (41, 42).
- 3) Completo viti (43) e guarnizione (31.1).

- ⊕ +F Con flange DN 40 PN 16
- ⊗ +R Con camera di preriscaldamento attorno al corpo
- ⊕ +R2 Con camera di preriscaldamento sul coperchio
- ⊕ +Y Con by-pass
- ⊕ +YY Con doppio by-pass
- ⊕ +02 Con oliatore da 0.2 l in vetro
- ⊗ +Y+R2 Con by pass e camera di preriscaldamento sul coperchio

* Materiali di costruzione

- B4 = Bronzo AD4
- D = Guarnita o fibra
- E3 = Centellen VS 3820
- G = Ghisa
- GH = Ghisa sutfinizzata
- GR = Grafite
- GS = Ghisa sferoidale
- H = Acciaio inox AISI 304
- H2 = Acciaio inox AISI 420
- K = Acciaio inox AISI 316
- K9 = Acciaio inox AISI 329
- KNM = Acciaio inox AISI 316 + Nitrurazione morbida
- S = Acciaio
- SH = Acciaio trattato
- TE = Teflon
- T3 = Acciaio K100
- W = Carburo di Tungsteno

Ordinare il materiale indicando sempre la quantità, la denominazione, il codice del pezzo, il tipo ed il numero della pompa.

Notes:

- 1) Complete with gasket (01.2) and plug (01.1).
- 2) Complete with keys (41, 42).
- 3) Complete with screws (43) and gasket (31.1).

- ⊕ +F With DN 40 PN 16 flanges
- ⊗ +R Heating jacket cast integral with the casing
- ⊕ +R2 Heating jacket on cover
- ⊕ +Y With by-pass
- ⊕ +YY With double by-pass
- ⊕ +02 With 0.2 l glass oil lubricator
- ⊗ +Y+R2 With by-pass and heating jacket on cover

* Construction materials

- B4 = AD4 Bronze
- D = Guarnita or fiber
- E3 = Centellen VS 3820
- G = Cast iron
- GH = Sulfured cast iron
- GR = Graphite
- GS = Ductile cast iron
- H = AISI 304 stainless steel
- H2 = AISI 420 stainless steel
- K = AISI 316 stainless steel
- K9 = AISI 329 stainless steel
- KNM = AISI 316 stainless steel + liquid nitriding
- S = Steel
- SH = Hardened steel
- TE = Teflon
- T3 = K100 steel
- W = Tungsten carbide

When ordering spares always indicate type and serial number of pump, quantity, part name, and number.



Dosierpumpen, Chemiekreiselpumpen, Schlamm- und Abwasserpumpen, Anlagen zum Reinigen industrieller Abluft

ZIER Pumpen und Anlagen AG
CH -9323 Steinach

Telefon: (++41) 71 446 00 00
Fax: (++41) 71 446 00 05

E-Mail: info@zier-anlagenbau.ch
Internet: www.zier-anlagenbau.ch