

Pos. V

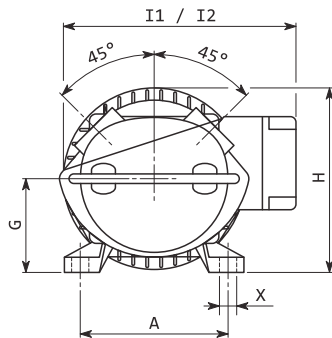

Pos. 90D

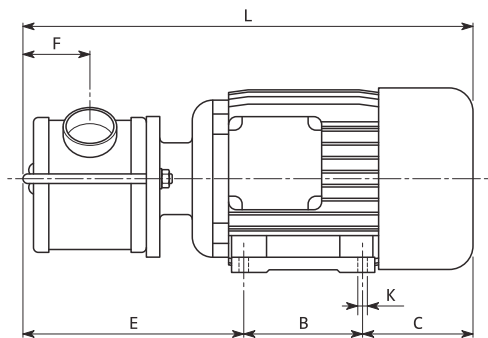
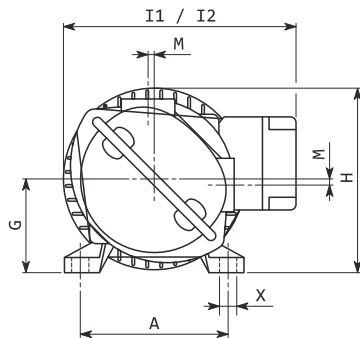
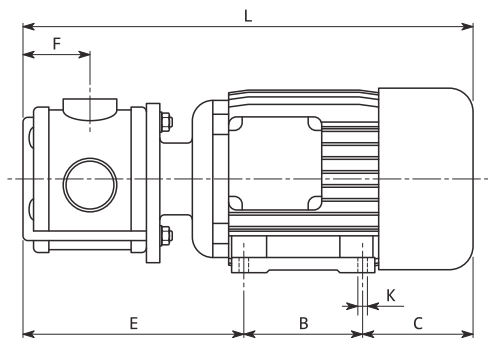

Pos. 90S

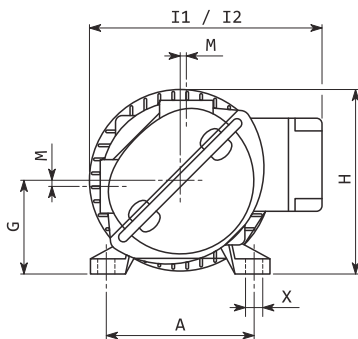
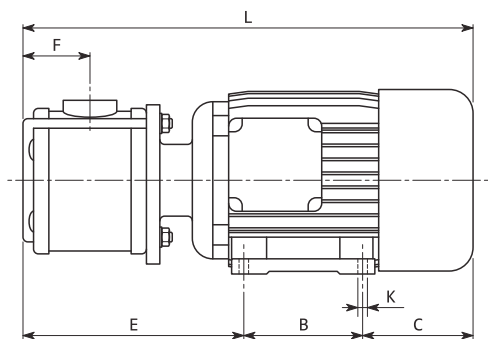

Typ Type	Motor	Speed	A	B	E	F	G	H	I1*	I2*	L	M	K	X
NIROSTAR 2000-C	M80	1	125	100	148	38	80	159	200	227	338	7	8	16
	M80	2	125	100	148	38	80	159	-	227	338	7	8	16
NIROSTAR 2000-D	M90	1	140	125	198	60	90	180	210	240	420	4.5	10	16
	M100	2	160	140	210	60	100	198	-	260	455	4.5	12	21
NIROSTAR 2000-E	M100	1	160	140	253	70	100	198	245	263	490	6.5	12	21
	M112	1	190	140	259	70	112	225	275	-	514	6.5	12	22
NIROSTAR 2000-F	M132	1	216	178	312	90	132	261	320	-	630	13	12	22

I1* = Motor mit Klamm Brett-Anschluss
 I2* = Motor mit Ein/Aus- Drehumkehrschalter